

Advancements In Antennas

Antennas For All Your EMC Applications

AR's EMC Applications Engineers and Antenna Designers are continually working together to develop antennas which not only meet today's test requirements, but greatly improve test efficiency as well. This is achieved through wider beamwidths and frequency bands, thus reducing the need for using multiple antennas to cover required bands.

Our Radiant Arrow bent element antennas – for fields from 26 MHz to 6,000 MHz – are about 60% smaller, lighter and more compact than standard log-periodic antennas. Yet they cover broad frequency ranges, offer up to 6dBi gain, and produce high fields even in the toughest applications. The smaller size not only makes them more portable, it minimizes field loss from “room loading.”

Our newest Radiant Arrow antenna pushes the boundaries even further. The ATR26M1G (26 – 1000 MHz / 20,000 watts input power) goes beyond existing susceptibility requirements, so it's ready for future developments. And the robust design accommodates the high power levels needed to generate significant E-fields.

AR is also THE source for microwave and RF horn antennas, broadband log-periodics, and antennas for HIRF testing. Antennas are available up to 50 GHz and 20,000 watts of input power. All AR antennas develop high fields, suitable for RF and EMC testing, and many models can be calibrated for emissions testing.

All our antennas are frequency and power-matched to AR amplifiers, so it's easy to select the right unit.



ATH800M6G
High Gain Horn Antenna
 800 MHz to 6 GHz; Up to 2.3 kW,
 Up to 2000 V/m @ 1m. Ideal for HIRF
 testing of Aircraft, Automotive and
 Military applications. High gain
 and high power handling.



ATT700M12G
Trapezoidal Log Periodic Antenna
 700 MHz to 12 GHz
 Broad, Uniform Beam
 Up to 600 W; Up to 200 V/m
 @ 1m. Ideal for IEC 61000-4-3
 and telecom testing. Furthermore,
 its wide beamwidth and small physical
 size makes this antenna desirable for small
 chambers. This is an all-purpose antenna that
 can be used in many other applications.



ATR80M6G
Radiant Arrow Log Periodic Antenna
 80 MHz to 6 GHz; Up to 5 kW, Up
 to 500 V/m @ 1m. Ideal
 for covering the full
 testing range of
 IEC 61000-4-3 while
 providing excellent gain and
 beam width throughout the band.



ATE10K30MA
E-Field Generator
 10 kHz to 30 MHz Up to 3
 kW, Up to 200 V/m. Primary
 application is MIL-STD-461
 testing. It can also be used for
 automotive component testing.



Custom Striplines
 10 kHz to 30 MHz Typical Up to 20 kW
 Direct Feed or Step-up Transformer: Primary application
 is full-vehicle automotive testing. Also applicable to
 MIL-STD-464 testing of large military systems and can be
 designed to meet your specific needs.

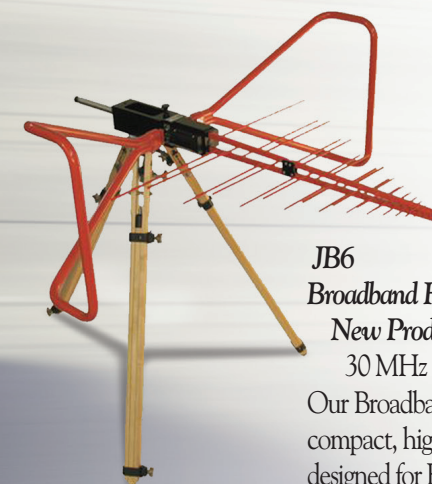

JB6
Broadband Hybrid Antenna
 New Product From **SUNAR**
 30 MHz - 6 GHz
 Our Broadband Hybrid Antennas are
 compact, high-performance instruments
 designed for EMC emissions
 and immunity testing.

Antennas
Radiant Arrow Antennas That Take Technology To New Heights



Quick Change Connectors
 Most antennas come with quick change connectors so you can easily change to accommodate various cabling and amplifier outputs.

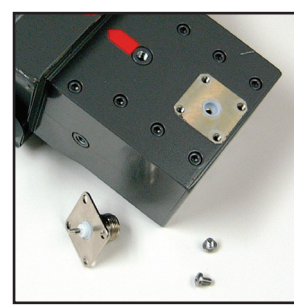
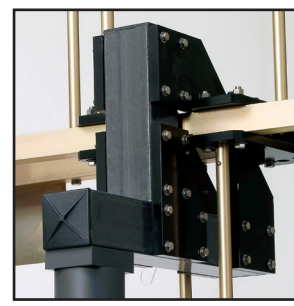
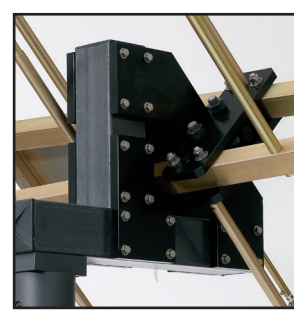
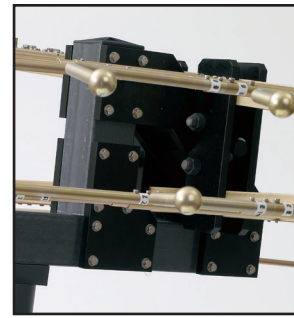

Model ATR26M6G-1 shown on model TP1000B tripod.



Remove a pin and easily rotate the antenna to the desired position.

AR has advanced the science of log-periodic antennas with the unique, patented design of our Radiant Arrow bent element antennas - for fields from 26 MHz to 6 GHz.

This exceptional family of antennas includes the ATR80M6G (80 MHz - 6 GHz, 5,000 watts input power), the ATR26M6G and ATR26M6G-1 (26 MHz - 6 GHz, 5,000 watts input power) and the ATR26M250 (26 MHz - 250 MHz, 15K watts input power).

The Radiant Arrows utilize a "bent-element" approach that provides a size reduction up to 75% without sacrificing key electrical performance such as gain or bandwidth. The size reduction minimizes field loss resulting from "room loading" - which is especially troublesome when conventional log-periodic antennas are used in small enclosures. All four models feature a vertical to horizontal pivot to allow bore sight rotation without removing an element from the antenna or removing the antenna from the AR positioner.

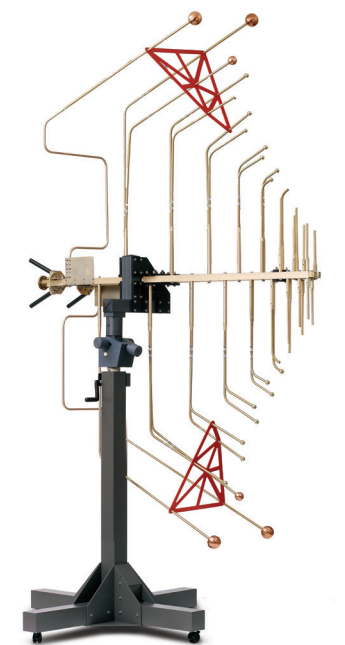
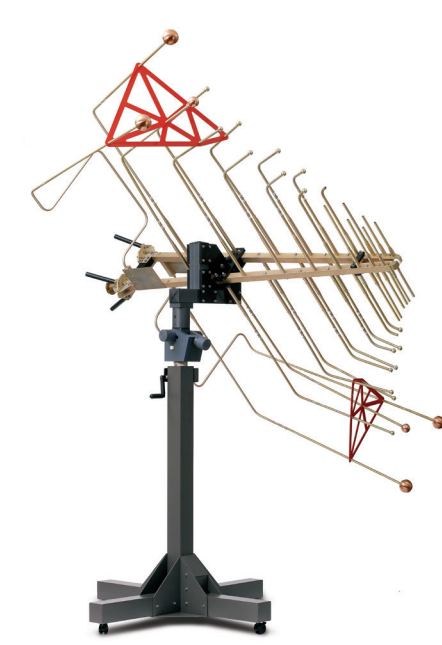

ATR26M1G

26 MHz to 1000 MHz

The Model ATR26M1G is a wideband, high gain, log periodic antenna that is uniquely suited for use in both traditional applications as well as in new compact chambers. The proprietary design, utilizing a “bent element” approach combined with additional innovations, provides a size reduction of approximately 75% without sacrificing key electrical performance such as gain and beamwidth. The reduced profile and extremely low VSWR make it an excellent choice for high field-strength immunity testing, and the robust design can accommodate the high power levels necessary to generate significant E-fields. The ATR26M1G can also be calibrated for RF emissions testing.

Can be custom calibrated to the user's requirement for use in RF emission testing. The calibrated model is designated by adding a 'CC' suffix to the desired model version. Calibration details must be provided using Form 701. Contact factory for details.



ATR26M1G

FIELD STRENGTH MEASURED AT 1 METER

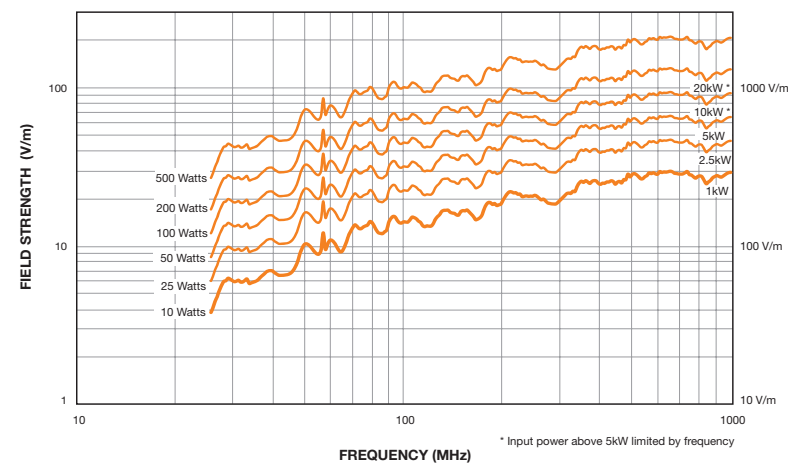

FIELD STRENGTH MEASURED AT 3 METERS

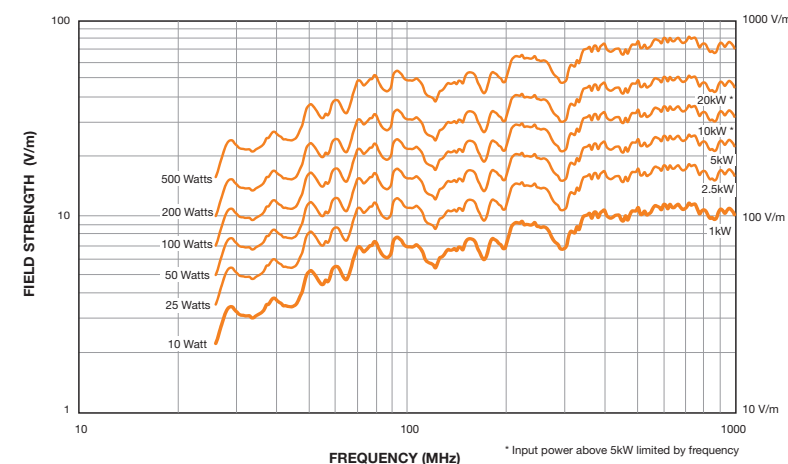

Specifications

ATR26M1G

Frequency range	26 - 1000 MHz
Power input, CW	20 kW @ 26 MHz, derate to 5 kW @ 1000 MHz
Gain (over isotropic)	- 8 to 0 dB (26 - 80 MHz) 0 - 6 dB (80 - 1000 MHz)
Gain flatness	±3 dB (80 - 1000 MHz)
Impedance	50 ohms nominal
VSWR (max.)	6:1 (26 - 80 MHz) 3:1 (80 - 1000 MHz)
Beamwidth (average)	Typical curves available on request
Connector	1 5/8 EIA male with removable center bullet
Size (W X H X D)	231 x 66 x 183 cm (91 x 26 x 72 in)
Weight (max.)	29.5 kg (65 lb)
Mounting	May be mounted in two perpendicular planes using an optional antenna positioner (AP5010B). One non-metallic mast (4 foot) is included for vertical mounting.

ATR26M6G-1

26 MHz to 6 GHz

The new Model ATR26M6G-1 is uniquely suited for use in both traditional applications and in compact test chambers. Its exceptionally broad frequency range addresses existing RF susceptibility requirements as well as anticipated developments. The ATR26M6G-1 features a 75% size reduction over standard log periodic antennas covering this frequency range. It is matched to work directly with AR's “W,” “S” and “A” series RF power amplifiers. The robust design can accommodate the high power levels necessary to generate significant E-fields. The ATR26M6G-1 can also be calibrated for RF emissions testing. The antenna can be supported with the AP5010B antenna positioner, or the TP1000BM3 with ballast tray.

Can be custom calibrated to the user's requirement for use in RF emission testing. The calibrated model is designated by adding a 'CC' suffix to the desired model version. Calibration details must be provided using Form 701. Contact factory for details.



ATR26M6G-1

FIELD STRENGTH MEASURED AT 1 METER

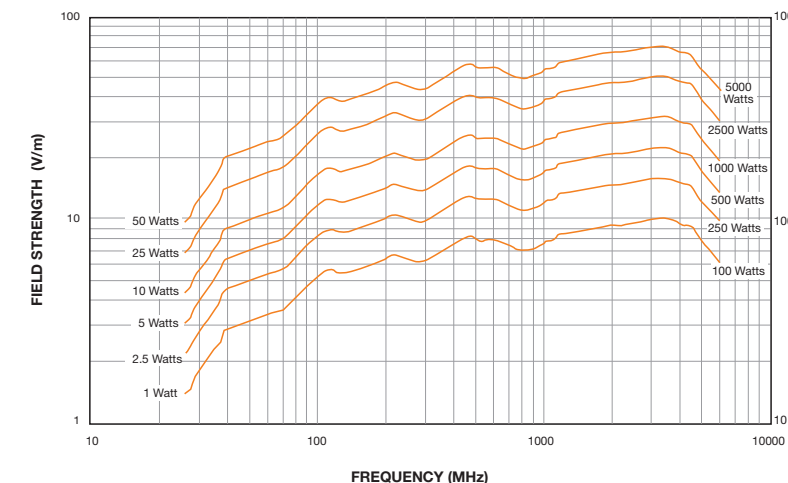

FIELD STRENGTH MEASURED AT 3 METERS

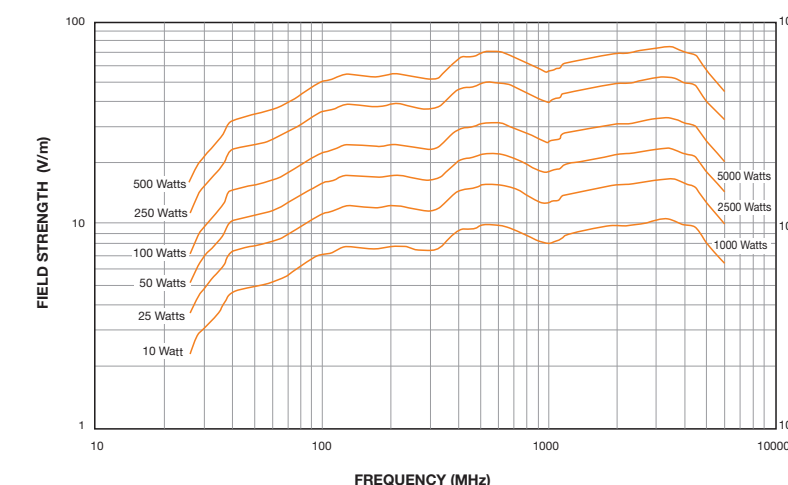

Specifications

ATR26M6G-1

Frequency range	26 MHz - 6 GHz
Power input (max.)	5000 watts
Gain (over isotropic)	- 4 to 6 dB (26 - 80 MHz) 6 dB (80 MHz - 6 GHz)
Gain flatness	±1.5 dB (80 MHz - 6 GHz)
Impedance	50 ohms nominal
VSWR (max.)	6:1 (26 - 80 MHz) 3:1 (80 MHz - 6 GHz)
Beamwidth (average)	Typical curves available on request
Connector	Type N (F) quick change connector; Type C (F) supplied for higher power applications
Size (W X H X D)	218.4 x 73.7 x 161.3 cm (86 x 29 x 63.5 in)
Weight (max.)	13.6 kg (30 lb)
Mounting	May also be mounted using the optional AP5010B antenna positioner or the TP1000BM3 tripod with ballast tray. Also includes 2 non-metallic masts (4 and 6 feet) vertical mounting.

Field strengths have been measured in free-space conditions. Individual shielded rooms, amplifiers, and test-system conditions will influence performance. Field strength also varies with frequency and position of antenna and EUT in non-anechoic testing environments.

Antennas The Most Advanced Antennas For Radiated EMC Testing

a: ATR26M250 - 26 to 250 MHz

b: ATR26M6G - 26 MHz to 6 GHz

c: ATR80M6G - 80 MHz to 6 GHz

d: ATR200M6G - 200 MHz to 6 GHz

Our Radiant Arrows offer up to 6dBi gain and produce high fields even in the toughest applications. They can also be calibrated for emissions testing. These efficient, compact, portable antennas represent the innovative thinking and exceptional products that have earned AR the Number One position in the industry.

Antenna Mounting Adapters

Available for older versions of the AT1000, AT1080 and AT5080 antennas. Allows for vertical & horizontal polarization changes without removing the antenna from the tripod.

Can be custom calibrated to the user's requirement for use in RF emission testing. The calibrated model is designated by adding a 'CC' suffix to the desired model version. Calibration details must be provided using Form 701. Contact factory for details.

Specifications	ATR26M250	ATR26M6G	ATR80M6G	ATR200M6G
Frequency range	26 - 250 MHz	26 MHz - 6 GHz	80 MHz - 6 GHz	200 MHz - 6 GHz
Power input (max.)*	15,000 watts	5,000 watts	5,000 watts	5,000 watts
Gain (over isotropic)	- 3 to +6 dBi (26 - 80 MHz) 6 dBi (80 - 250 MHz)	- 3 to +6 dBi (26 - 80 MHz) 6 dBi (80 MHz - 6 GHz)	6 dBi	6 dBi
Gain flatness	±1.5 dBi (80 - 250 MHz)	±1.5 dBi (80 - 6 GHz)	±1.5 dBi	±1.5 dBi
Impedance	50 ohms nominal	50 ohms nominal	50 ohms nominal	50 ohms nominal
VSWR (max.)	3:1 (80 - 250 MHz) 10:1 (26 - 80 MHz)	3:1 (80 - 6 GHz) 10:1 (26 - 80 MHz)	3:1 2:1 (typical)	3:1 2:1 (typical)
Beamwidth (avg.)	Typical curves available on request	Typical curves available on request	Typical curves available on request	Typical curves available on request
Connector	1 5/8 EIA quick change connector	Type N (F) quick change connector	Type N (F) quick change connector	Type N (F) quick change connector
Size (W X H X D)	279.4 x 53.6 x 202.4 cm (110 x 21.1 x 79.7 in)	279.4 x 53.6 x 202.4 cm (110 x 21.1 x 79.7 in)	132.1 x 20.32 x 97.8 cm (52 x 8 x 38.5 in)	82.6 x 17.8 x 57.2 cm (32.5 x 7 x 22.5 in)
Weight (max.)	31.8 kg (70 lb)	22.7 kg (50 lb)	7.94 kg (17.5 lb)	5 kg (12 lb)
Mounting	May be mounted in two perpendicular planes using an optional antenna positioner (AP5010B). One non-metallic mast (4 foot) is included for vertical mounting	May be mounted in two perpendicular planes using an optional antenna positioner (AP5010B). Two non-metallic masts (4 and 6 foot) are included for vertical mounting	May be tripod mounted in two perpendicular planes using optional tripod. Also includes one non-metallic mast for vertical mounting.	May be tripod mounted in two perpendicular planes using optional tripod. Also includes one non-metallic mast for vertical mounting.

*Connector and frequency dependent. Contact factory for details.

Typical gain charts and antenna patterns are available for most antennas. Contact factory for more information.



Shown on model AP5010B

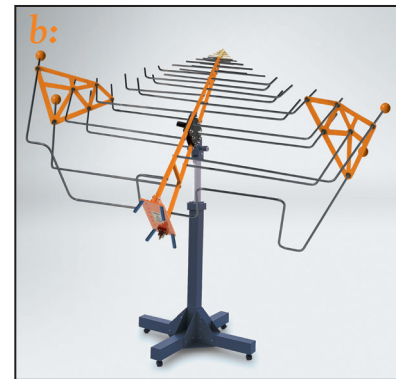

Shown on model AP5010B

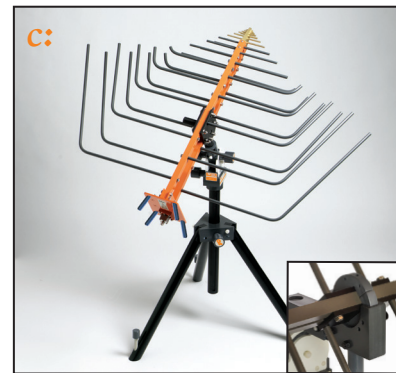

Shown on model TP1000B

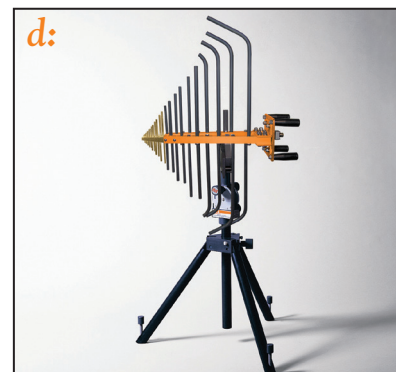

Shown on model TP1000B

ATR26M250

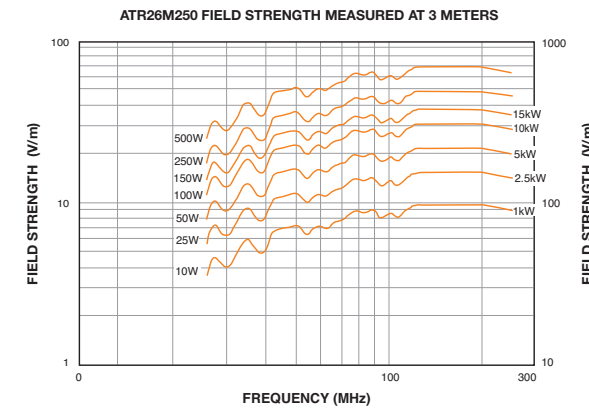
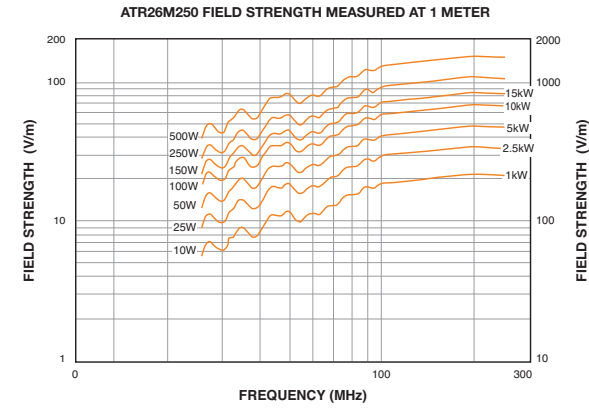

ATR26M6G

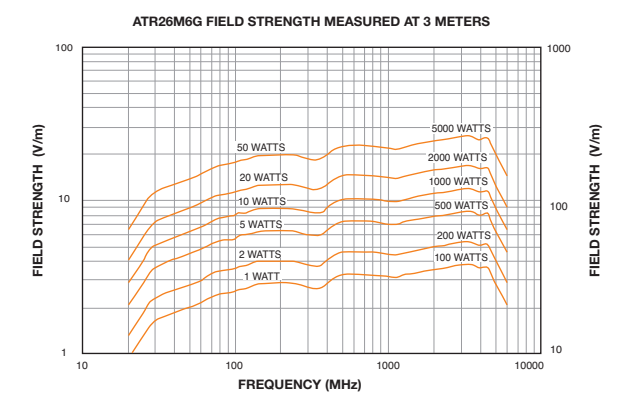
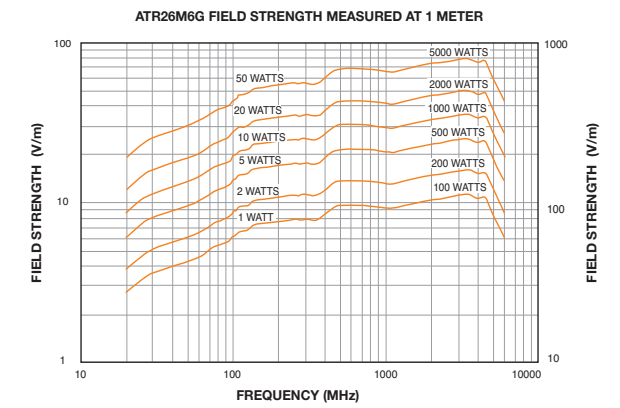

ATR80M6G

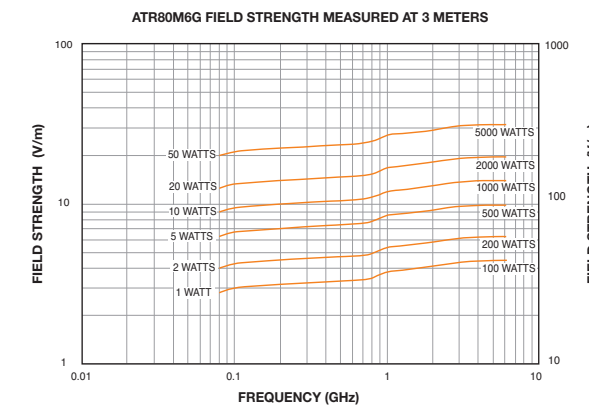
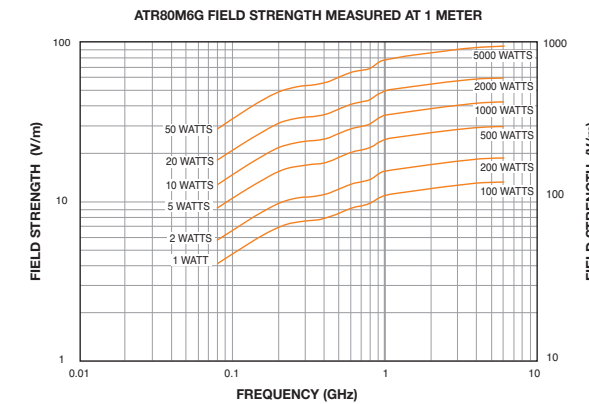

ATR200M6G

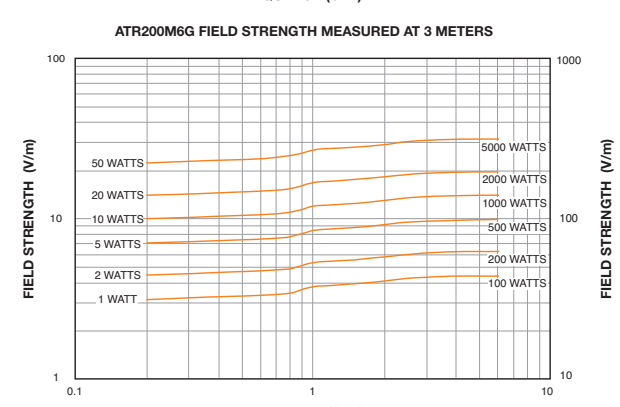
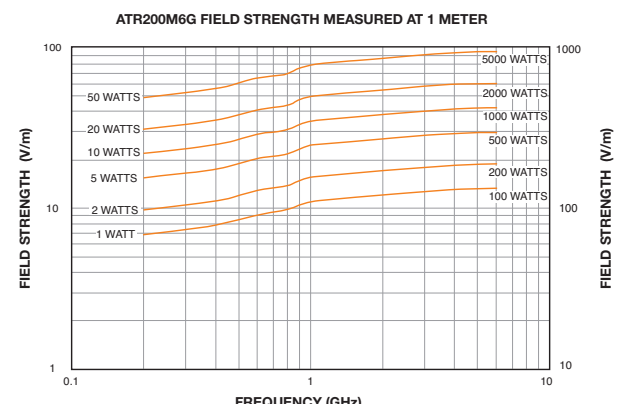

Field strengths have been measured in free-space conditions. Individual shielded rooms, amplifiers and test systems conditions will influence performance. Field strength also varies with frequency and position of the antenna and EUT in non-anechoic testing environments.

Antennas Broadband Log-periodic. High Gain. Wide Band. Excellent Performance.

a: ATL80M1G

b: ATL150M1G

80 MHz to 1 GHz • To 800 V/m

You can count on AR's high gain log-periodics to deliver the constant high intensity fields you need for RFI and EMI testing, in and out of a shielded room. You'll also get frequency response and field intensity that goes beyond the norm.

Their lightweight, compact design makes relocation easy and they can easily be mounted on a flat surface or tripod. And these antennas are built tough to stand up to the outdoors.

These antennas have been designed to allow polarization change without removing the antenna from a tripod, and can be calibrated for emissions testing.

Can be custom calibrated to the user's requirement for use in RF emission testing. The calibrated model is designated by adding a 'CC' suffix to the desired model version. Calibration details must be provided using Form 701. Contact factory for details.



ATL80M1G

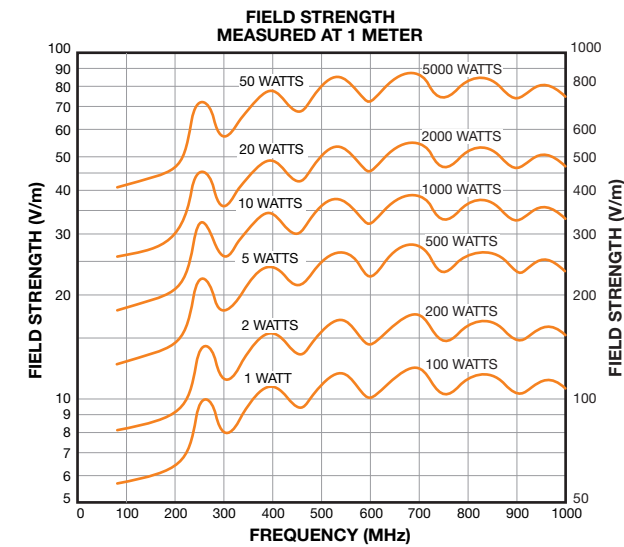

Note: Curves above 1000 and 2000 watts do not apply past power-frequency limits of the antenna.

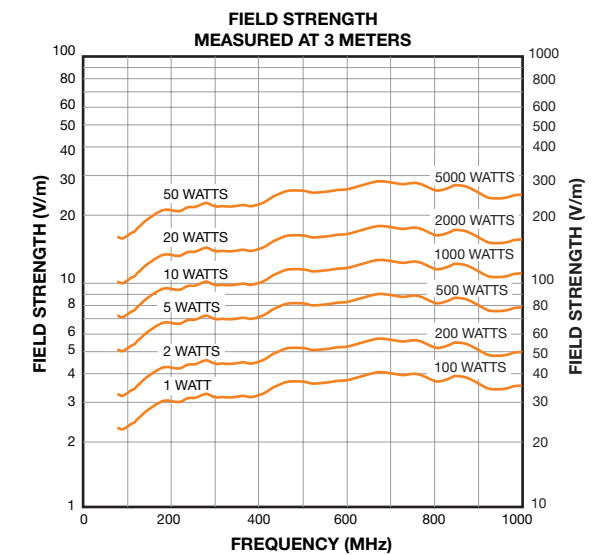

ATL150M1G

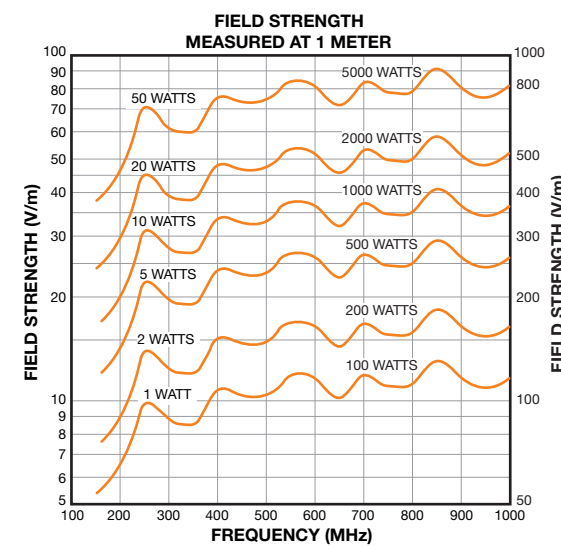

Note: Curves above 1000 and 2000 watts do not apply past power-frequency limits of the antenna.

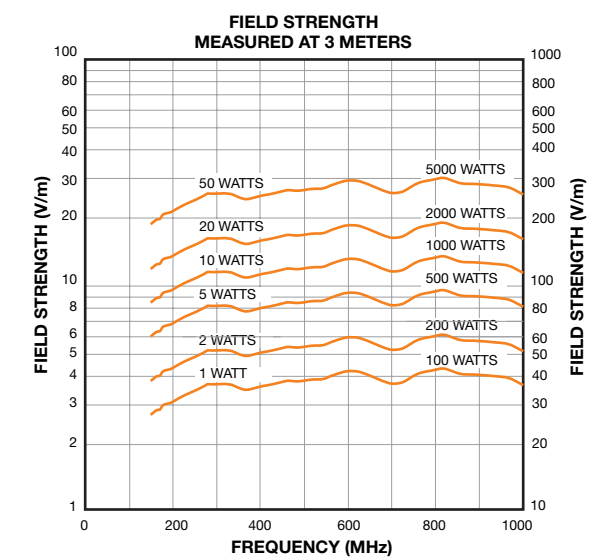

Specifications

	ATL80M1G	ATL150M1G
Frequency range	80 - 1,000 MHz	150 - 1,000 MHz
Power input (max.)	2,000 watts	2,000 watts
Gain (over isotropic)	6.5 dBi min., 7.5 dBi avg.	6.5 dBi min., 7.5 dBi avg.
Gain flatness	±1.0 dBi	±1.0 dBi
Impedance	50 ohms nominal	50 ohms nominal
VSWR	1.8:1 (max.) 1.5:1 (average)	1.8:1 (max.) 1.5:1 (average)
Beamwidth (average)	E plane 60° H plane 105°	E plane 60° H plane 105°
Front to back ratio (min.)	15 dB	15 dB
Connector	Type N (F) quick change connector; Type C (F) supplied for higher power applications	Type N (F) quick change connector; Type C (F) supplied for higher power applications
Size (W X H X D)	193 x 13 x 160 cm (76 x 5.1 x 63 in)	102 x 13 x 91 cm (40 x 5.1 x 36 in)
Weight (max.)	7 kg (15 lb)	7 kg (15 lb)
Mounting	May be mounted using the optional TP1000B tripod.	May be mounted using the optional TP1000B tripod.

Field strengths have been measured in free-space conditions. Individual shielded rooms, amplifiers, and test-system conditions will influence performance. Field strength also varies with frequency and position of antenna and EUT in non-anechoic testing environments.

Antennas Wide Band, High Gain, Trapezoidal Log-Periodic Antennas.

ATT700M8G

700 MHz to 7.5 GHz

The newest addition to our family of high gain, log-periodic antennas, model ATT700M8G is a wideband trapezoidal log-periodic antenna and handles twice the power of the ATT700M12G. It provides high power handling, nearly constant gain, and wide beam widths, which are nearly equal in the E and H planes. It is designed to complement AR's S-Series amplifiers and is compact, lightweight and easily mounts to a tripod using the included adapter.



ATT700M8G

FIELD STRENGTH MEASURED AT 1 METER

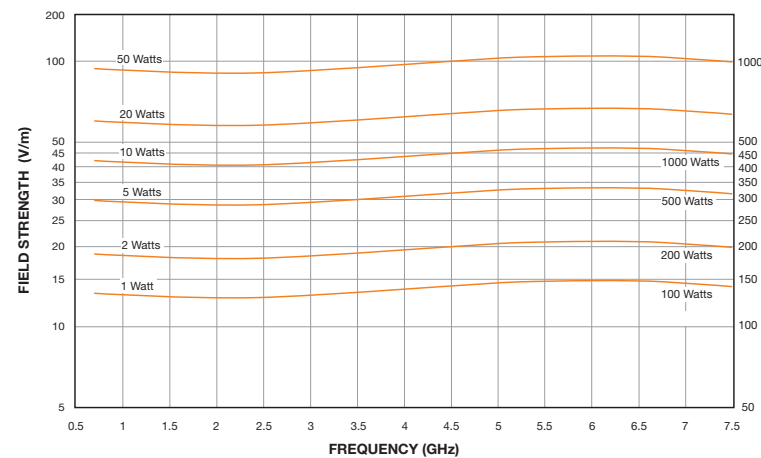

FIELD STRENGTH MEASURED AT 3 METERS

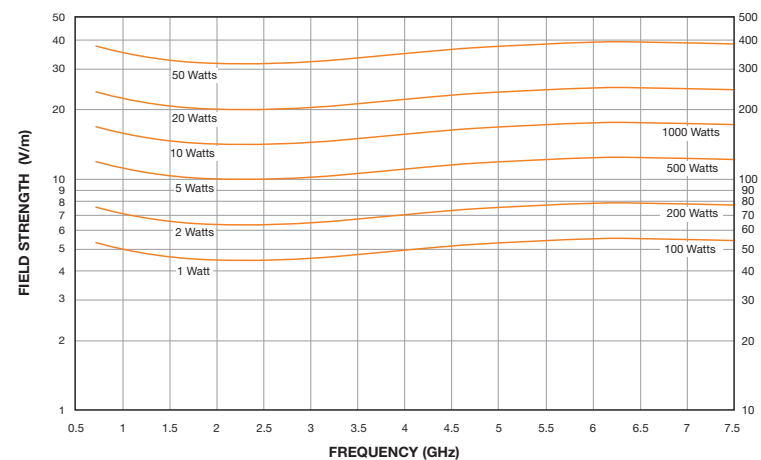

Specifications

ATT700M8G

Frequency range	700 MHz - 7.5 GHz
Power input (max.)	1200 watts max.
Gain (over isotropic)	8 dBi typ.
Gain flatness	±1.5 dBi
Impedance	50 ohms nominal
VSWR	3:1 (max.) 1.7:1 (average)
Beamwidth (average)	E plane 57° H plane 60°
Connector	7-16 DIN (F)
Size (W X H X D)	28 x 28 x 56 cm (11 x 11 x 22 in)
Weight (max.)	1.8 kg (4 lbs)
Mounting	May be tripod mounted with included mount.

ATT700M12G

700 MHz to 12 GHz

The ATT700M12G is a wideband trapezoidal log-periodic antenna. It provides high power handling, nearly constant gain, and wide beam widths, which are nearly equal in the E and H planes. It is designed to complement AR's S-Series amplifiers and is compact, lightweight and easily mounts to a tripod using the included adapter.



ATT700M12G

FIELD STRENGTH MEASURED AT 1 METER

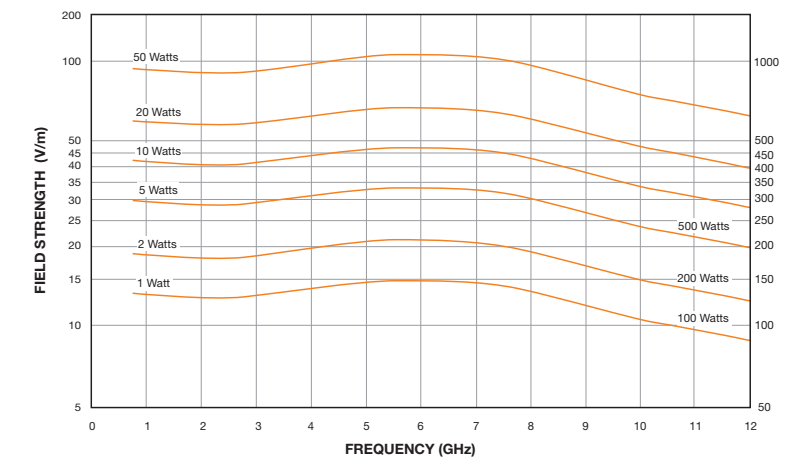

FIELD STRENGTH MEASURED AT 3 METERS

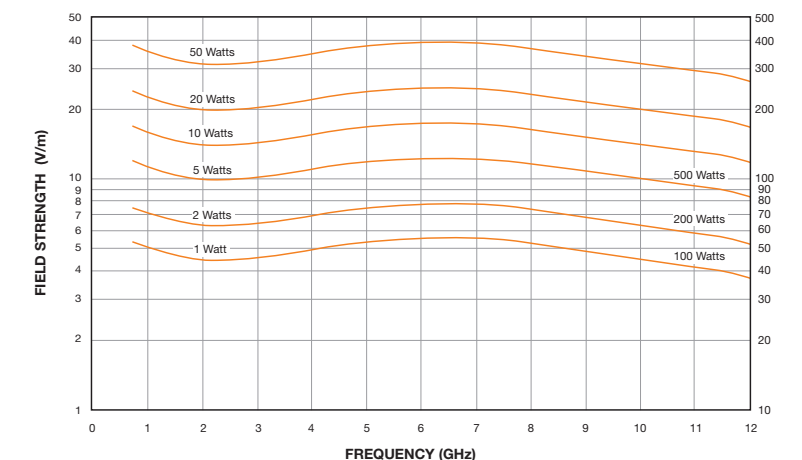

Specifications

ATT700M12G

Frequency range	700 MHz - 12 GHz
Power input (max.)	600 watts max.
Gain (over isotropic)	8 dBi typ.
Gain flatness	±1.5 dBi
Impedance	50 ohms nominal
VSWR	3:1 (max.) 1.7:1 (average)
Beamwidth (average)	E plane 57° H plane 60°
Connector	Type N (F)
Size (W X H X D)	28 x 28 x 55 cm (11 x 11 x 21.5 in)
Weight (max.)	1.7 kg (3 lbs, 12 oz)
Mounting	May be tripod mounted with included mount.

Field strengths have been measured in free-space conditions. Individual shielded rooms, amplifiers, and test-system conditions will influence performance. Field strength also varies with frequency and position of antenna and EUT in non-anechoic testing environments.

Antennas RF Horns. High Gain Over A Broad Spectrum.

- a: ATH200M1G
- b: ATH200M1G-1
- c: ATH400M1G

200 To 1,000 MHz • To 800 V/m

Our RF horn antennas exhibit increasing gain with frequency up to 18 dBi at 1,000 MHz, helping to compensate for losses that occur elsewhere in an RF test system. The ATH200M1G handles up to 5,000 watts input power and can be used with AR's high power amplifiers. You can use these antennas in shielded rooms for free space testing.

Can be custom calibrated to the user's requirement for use in RF emission testing. The calibrated model is designated by adding a 'CC' suffix to the desired model version. Calibration details must be provided using Form 701. Contact factory for details.

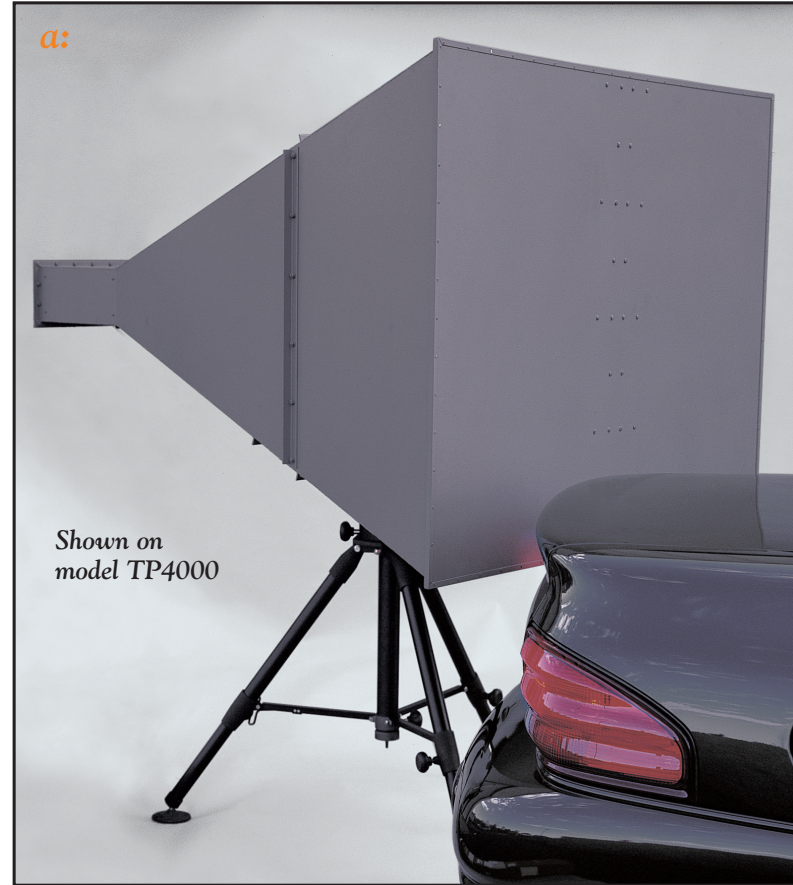

ATH200M1G

FIELD STRENGTH MEASURED AT 1 METER

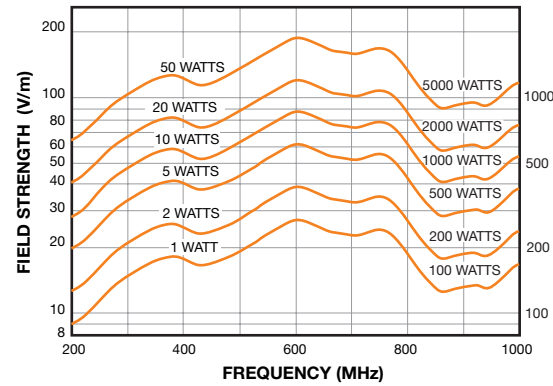

FIELD STRENGTH MEASURED AT 3 METERS

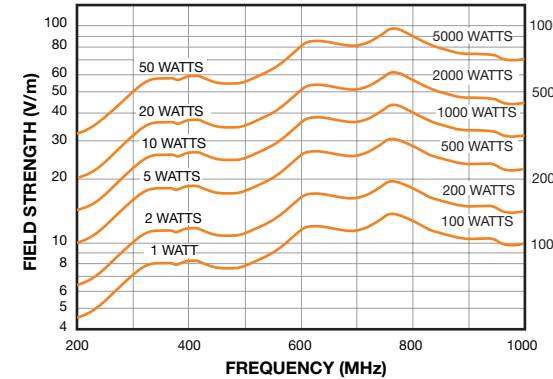

ATH200M1G-1

FIELD STRENGTH MEASURED AT 1 METER

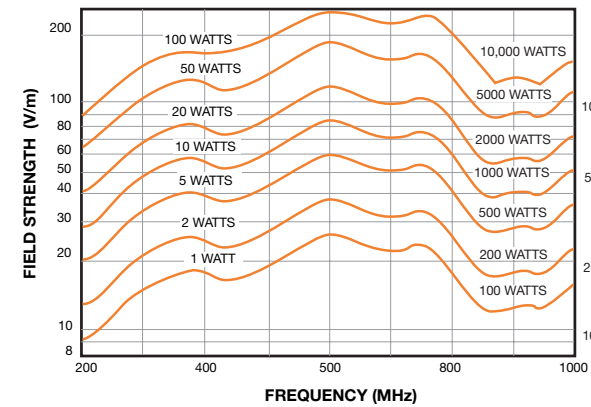

FIELD STRENGTH MEASURED AT 3 METER

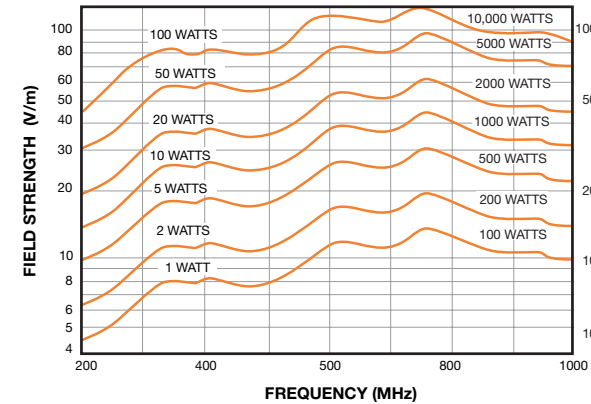

ATH400M1G

FIELD STRENGTH MEASURED AT 1 METER

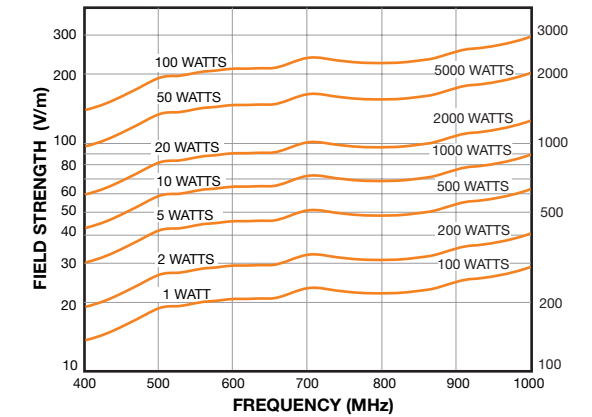

FIELD STRENGTH MEASURED AT 3 METERS

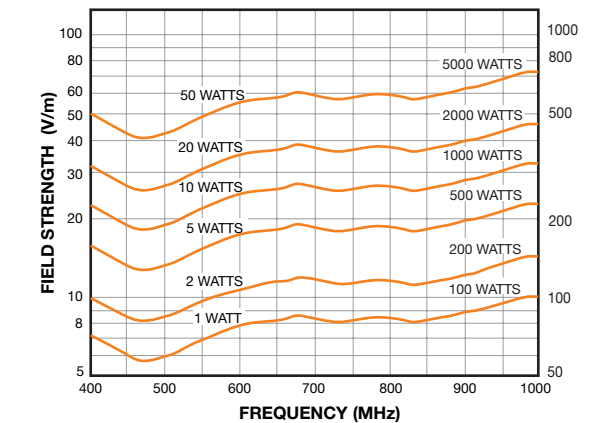

Specifications

	ATH200M1G	ATH200M1G-1	ATH400M1G
Frequency range	200 - 1,000 MHz	200 - 1,000 MHz	400 - 1,000 MHz
Power input (max.)	5,000 watts	10,000 watts	See graph
Gain (over isotropic)	10 dBi min., typically increasing to 18 dBi at 1,000 MHz	10 dBi min., typically increasing to 18 dBi at 1,000 MHz	10 dBi min., typically increasing to 15 dBi at 1,000 MHz
Impedance	50 ohms nominal	50 ohms nominal	50 ohms nominal
VSWR	2.5:1 max., 1.5:1 avg.	2.5:1 max., 1.5:1 avg.	2.5:1 max., 1.5:1 avg.
Beamwidth (front to back)	Typical curves available on request	Typical curves available on request	See curve
Connector	Type 1- 5/8 EIA Flange, Quick Change Connector	Type 1- 5/8 EIA Flange	Quick Change block. See Model Configurations.
Mounting	Heavy-duty tripod included. Pads with 3/8-16 thread for stand mounting vertically or horizontally.	Pads with 3/8-16 thread for stand mounting vertically or horizontally.	Rear flange for wall mount. Pads with 1/4-20 thread for tripod mount.
Weight	46 kg (100 lb)	46 kg (100 lb)	9.1 kg (20 lb)
Size (W X H X D)	109.2 x 145.8 x 175.3 cm (43 x 57 x 69 in)	109.2 x 145.8 x 175.3 cm (43 x 57 x 69 in)	56.4 x 79.3 x 73.7 cm (22.2 x 31.2 x 29 in)

Field strengths have been measured in free-space conditions. Individual shielded rooms, amplifiers, and test-system conditions will influence performance. Field strength also varies with frequency and position of antenna and EUT in non-anechoic testing environments.

a: ATH2G4 - 2 to 4 GHz

b: ATH4G6 - 4 to 6 GHz

c: ATH6G8 - 6 to 8 GHz

A Special Family of Antennas for High Intensity Radiated Field (HIRF) Testing

High fields - whether from radar or other electronic devices, or generated by enemy/terrorist forces - can cause electronic equipment to malfunction, stop working, or worse. Our amplifiers and antennas are critical components in generating high intensity fields for testing electronic equipment. To keep up with the demands of HIRF testing, AR has developed a new family of antennas with the power and bandwidth needed for high field testing.

These are all high-gain, high-power microwave horn antennas that provide typical 20 dBi over isotropic. They supply high intensity fields for aviation and military HIRF testing. They are extremely compact and lightweight for easy mobility. Yet they're built tough to withstand the demands of outdoor use. All three antennas are designed to mount easily on a tripod or to a mounting plate; and can be used with AR's pulsed-power traveling wave tube amplifiers.

Can be custom calibrated to the user's requirement for use in RF emission testing. The calibrated model is designated by adding a 'CC' suffix to the desired model version. Calibration details must be provided using Form 701. Contact factory for details.

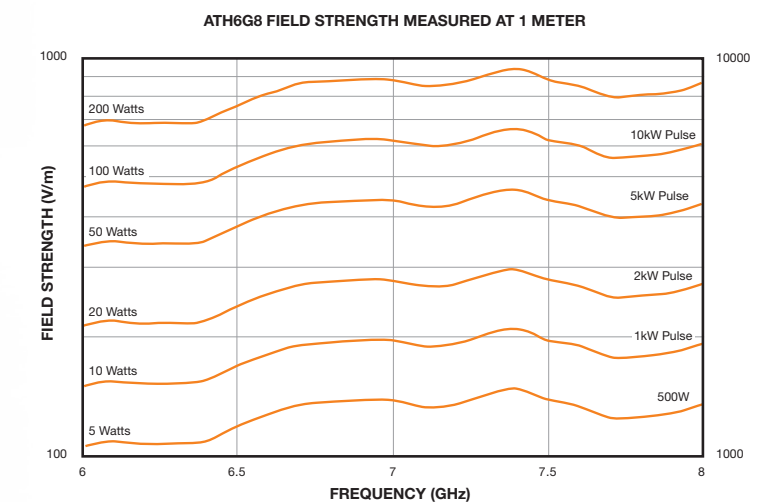
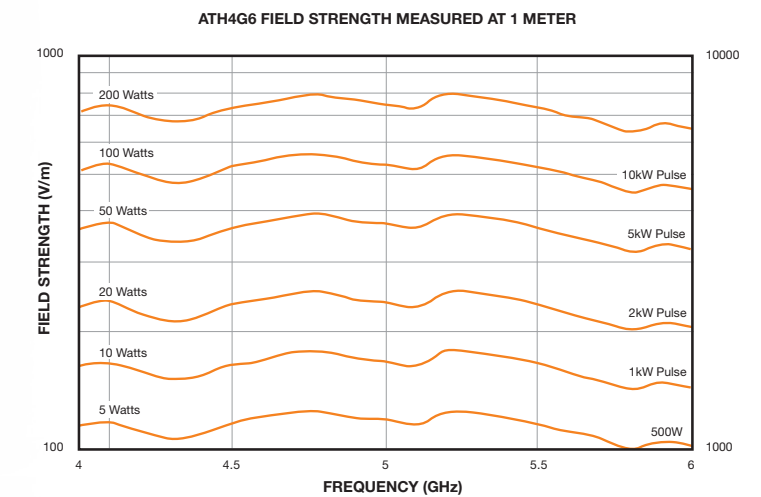
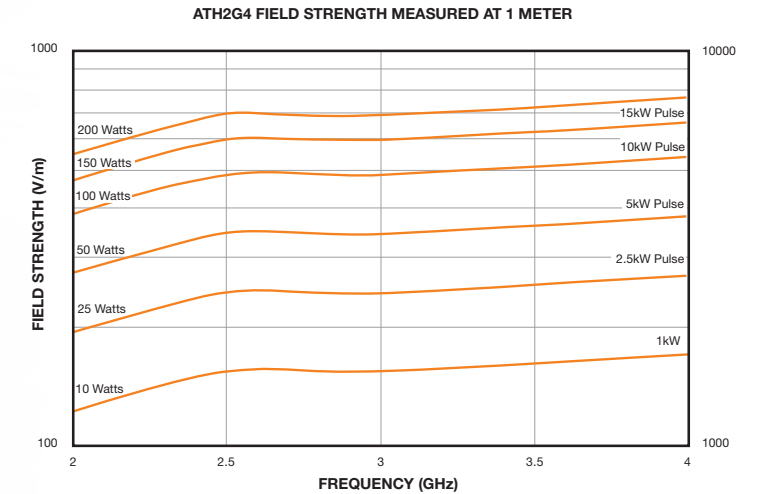

d: Tripod TP1000B

Specifications	ATH2G4	ATH4G6	ATH6G8
Frequency range	2 - 4 GHz	4 - 6 GHz	6 - 8 GHz
Power input (max.)	1,000 watts CW	800 watts CW	700 watts CW6 - 7.5 GHz 600 watts CW7.5 - 8 GHz
Peak Pulse less than 20%	17 kW Peak Pulse (1% duty cycle 6µs pulse width)	15 kW Peak Pulse (1% duty cycle 6µs pulse width)	10 kW Peak Pulse (1% duty cycle 6µs pulse width)
Gain (over isotropic)	17 dBi min.	18 dBi typ.	18 dBi typ.
VSWR			
Max.	1.5:1	1.5:1	1.5:1
Average	1.3:1	1.3:1	1.3:1
Beamwidth (avg.)			
E Plane	18°	19°	19°
H Plane	16°	19°	19°
Connector	7-16 DIN connector	7-16 DIN connector	7-16 DIN connector
Weight	11.36 kg (25 lb)	1.59 kg (3.5 lb)	91 kg (2 lb)
Size (WxDxH)	46.55 x 29.4 x 98.50 cm (19 x 12 x 40.2 in)	23.11 x 17.01 x 46.99 cm (9.1 x 6.7 x 18.5 in)	16.25 x 12.06 x 39.37 cm (6.4 x 4.75 x 15.5 in)
Mounting	Mounting pad on the E-plane and H-plane for tripod	Mounting pad on the E-plane and H-plane for tripod	Mounting pad on the E-plane and H-plane for tripod

Field strengths have been measured in free-space conditions. Individual shielded rooms, amplifiers, and test-system conditions will influence performance. Field strength also varies with frequency and position of antenna and EUT in non-anechoic testing environments.

Antennas Compact, Lightweight Microwave Horns To 50 GHz

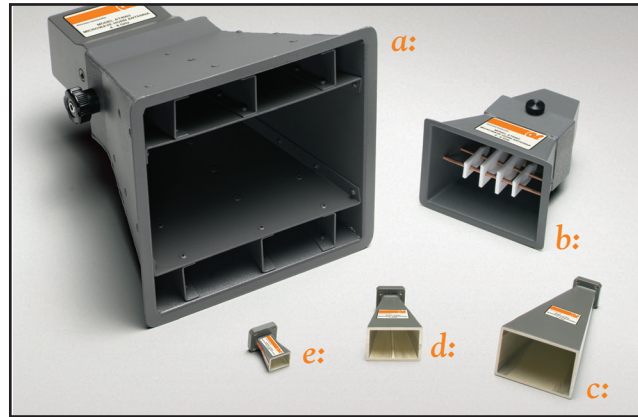

Field strengths have been measured in free-space conditions. Individual shielded rooms, amplifiers, and test-system conditions will influence performance. Field strength also varies with frequency and position of antenna and EUT in non-anechoic testing environments.

Even our microwave horns provide exceptional performance. Along with our broadband RF antennas, our microwave horns are specially designed to compensate for the losses that typically occur in test systems as frequency increases.

These innovative microwave horn antennas are compact and lightweight for easy mobility, yet they're tough enough for the extra demands of outdoor use, and they easily mount on a tripod. Several of our microwave horns have removable gain enhancers that improve the field strength to perform 3-meter testing.



Model
ATH800M6G



Model
ATH1G18A

Specifications	ATH200M2G	ATH1G18A
Frequency range	200 MHz - 2 GHz	1-18 GHz
Power input (max.)	1,000 watts	300 watts up to 7 GHz; above 7 GHz, derate linearly to 175 watts at 18 GHz
Gain (over isotropic)	6 dBi typ.	See curve
VSWR (typ.)	2:1	2:1
Beamwidth (avg.)		
E Plane	(beamwidth graph available on request)	(beamwidth graph available on request)
H Plane	(beamwidth graph available on request)	(beamwidth graph available on request)
Front To Back Ratio (Min.)	20 dBi	20 dBi
Connector	N (F) Precision	N (F) Precision
Weight	10.21 kg (22.5 lb)	1.8 kg (4 lb)
Size (WxDxH)	72.9 x 97.8 x 93.2 cm (28.7 x 38.5 x 36.7 in)	24.1 x 15.2 x 22.9 cm (9.5 x 6 x 9 in)

AR offers two wideband, double ridged microwave horn antennas for RFI/EMI testing. Due to the wide beam width, these two antennas are compliant to many military and commercial emissions standards. Both horns are compact and lightweight for easy mobility, yet are tough to withstand the extra demands of outdoor use.

- a: ATH4G8
- b: ATH7G18
- c: ATH18G27
- d: ATH18G27-1
- e: ATH26G40

Specifications	ATH800M5GA	ATH800M6G	ATH2G18	ATH2G10	ATH2G8A	ATH2G8A-1	ATH4G8	ATH6G18	ATH7G18	ATH18G27	ATH18G27-1	ATH18G40	ATH26G40	ATH26G40-1	ATH33G50
Frequency range	800 MHz - 5 GHz	800 MHz - 6 GHz	2 GHz - 18 GHz	2 - 10 GHz	2.5 - 7.5 GHz	2.5 - 7.5 GHz	4 - 8 GHz	6 - 18 GHz	7.5 - 18 GHz	18 - 26.5 GHz	18 - 26.5 GHz	18 - 40 GHz	26.5 - 40 GHz	26.5 - 40 GHz	33 - 50 GHz
Power input (max.)	2,300 watts (connector dependent)	2,300 watts (connector dependent)	50 watts	700 watts	12kW	12kW	500 watts	3kW max.	2,800 watts	350 watts	350 watts	450 watts	240 watts	240 watts	240 watts
Gain	11 dBi min, increasing to 21 dBi at 5 GHz	11 dBi min, increasing to 22 dBi at 6 GHz	6 dBi min, increasing to 12 dBi at 18 GHz	12.5 dBi min., increasing to 23 dBi at 10 GHz	9.5 dBi min, increasing to 18 dBi at 7.5 GHz.	12.5 dBi min, increasing to 22 dBi at 7.5 GHz.	11.5 dBi min., increasing to 15.9 dBi at 8 GHz	19 dBi min, increasing to 23 dBi at 18 GHz	11.3 dBi min., increasing to 14 dBi at 8 GHz	18.7 dBi min, increasing to 21.6 dBi at 26.5 GHz.	8.8 dBi min, increasing to 12 dBi at 26.5 GHz.	15.5 dBi min, increasing to 21.2 dBi at 40 GHz.	18.9 dBi min, increasing to 21.8 dBi at 40 GHz.	8.6 dBi min, increasing to 12.1 dBi at 40 GHz.	20 ± 2dBi
VSWR															
Max.	2.5:1	2.5:1	3.0:1	2:1	1.8:1	1.8:1	1.6:1	1.9 max., 6.5 - 18 GHz 2.5 max., 6.0 - 6.5 GHz	1.2:1	1.5:1	1.5:1	1.5:1	1.5:1	1.5:1	1.5:1
Average	1.6:1	1.6:1	2.0:1	1.5:1	1.3:1	1.3:1	1.3:1		1.1:1	1.3:1	1.3:1	1.3:1	1.3:1	1.35:1	1.2:1
Beamwidth (avg.) at 3dBi down from peak															
E Plane	27.5°	27.5°	50°	25°	30°	22°	18° with gain enhancer	14°	17° with gain enhancer	15°	55°	21°	15°	57.5°	9.85°
H Plane	25°	25°	50°	27°	30°	25°	18° with gain enhancer	15°	17° with gain enhancer	15°	56°	19°	15°	56.5°	11.9°
Connector	7-16 DIN (F), Type N(F) Quick change connector	7-16 DIN (F)	SMA (F)	N (F)	WRD-250-D30	WRD-250-D30	N (F) Quick change connector	WRD-650 D28 waveguide, cover flange, alternating thru/tapped hole pattern	WRD-750 waveguide	WR-42 waveguide	WR-42 waveguide	WRD-180 C24 waveguide	WR-28 waveguide	WR-28 waveguide	WR-22 waveguide
Weight	7.26 kg (16 lb)	7.26 kg (16 lb)	283.5g (10 oz.)	1.59 kg (3.5 lb)	1.18 kg (2.5 lb)	1.8 kg (4 lb)	2.27 kg (5 lb)	1.07 kg (2.36 lb)	0.6 kg (1.25 lb)	56.7 g (2 oz)	57 g (2 oz)	56.7 g (2 oz)	56.7 g (2 oz)	57 g (2 oz)	0.15 kg (0.33 lb)
Size (WxDxH)	46.3 x 46.3 x 69.2 cm (18.25 x 18.25 x 27.25 in)	46.3 x 46.3 x 69.2 cm (18.25 x 18.25 x 27.25 in)	12.64 x 8.23 x 9.85 cm (4.98 x 3.24 x 3.88 in)	22.9 x 17.8 x 31.75 cm (9 x 7 x 12.5 in)	12.2 x 9.9 x 20.3 cm (4.8 x 3.9 x 8 in)	18 x 14.5 x 33.5 cm (7.1 x 5.7 x 13.2 in)	without gain enhancer 7.62 x 10.3 x 15.14 cm (3.00 x 4.06 x 5.96 in) with gain enhancer: 21.6 x 21.6 x 30.5 cm (8.5 x 8.5 x 12 in)	17.7 x 12.7 x 30.8 cm (7 x 5 x 12.1 in)	without gain enhancer 4.6 x 6.1 x 6.4 cm (1.8 x 2.4 x 2.5 in) with gain enhancer: 8.9 x 11.4 x 13.3 cm (3.5 x 4.5 x 5.25 in)	5.74 x 4.09 x 11.4 cm (2.26 x 1.61 x 4.49 in)	1.63 x 1.32 x 2.92 cm (0.64 x 0.52 x 1.15 in)	3.73 x 2.69 x 6.27 cm (1.47 x 1.06 x 2.47 in)	4.06 x 3.07 x 7.67 cm (1.6 x 1.21 x 3.02 in)	1.30 x 1.09 x 2.16 cm (0.51 x 0.43 x 0.85 in)	4 x 3 x 9 cm (1.57 x 1.18 x 3.54 in)

Antennas Microwave Horns. Now To 50 GHz.

ATH200M2G

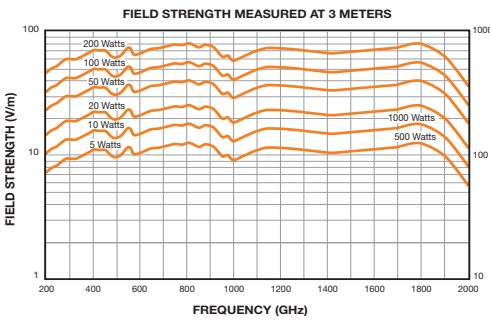
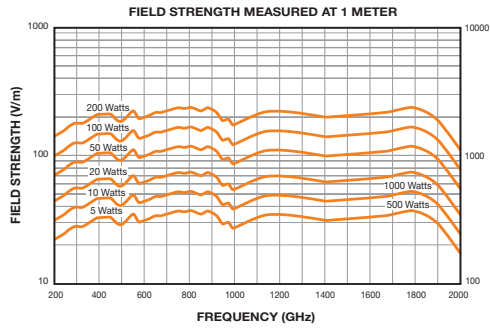

ATH800M5GA

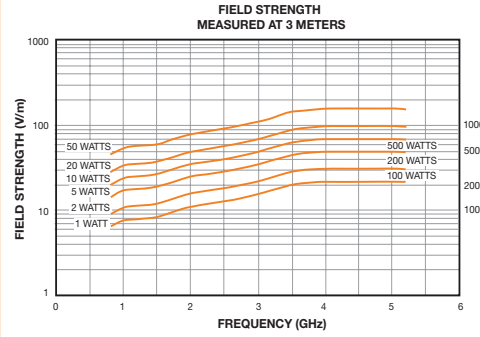
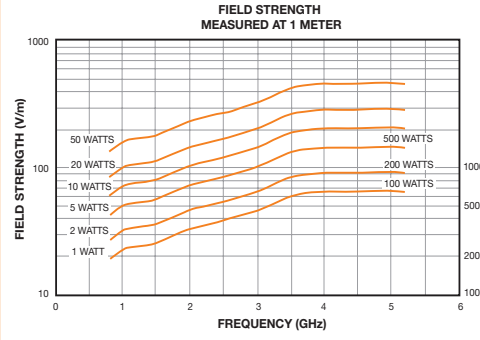

ATH800M6G

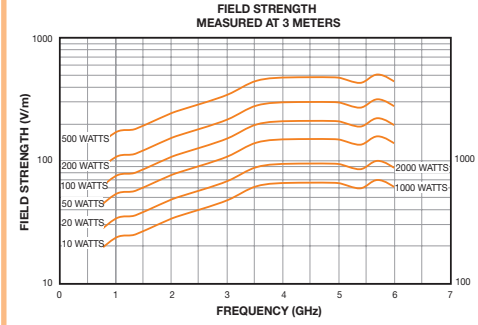
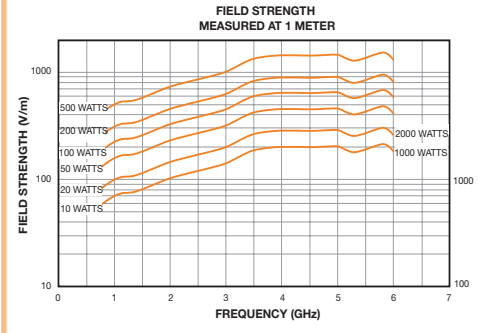

ATH2G10

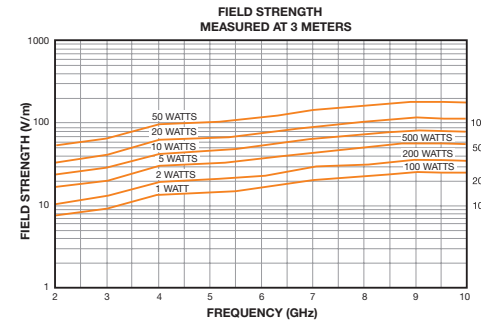
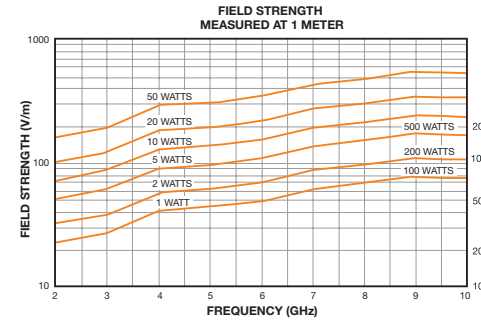

ATH2G18

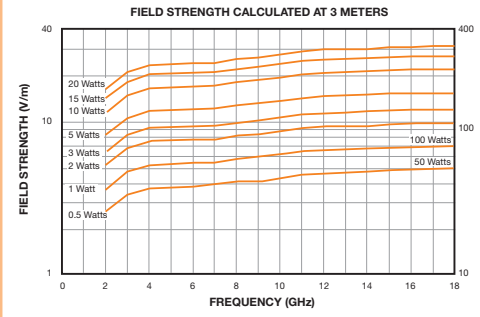
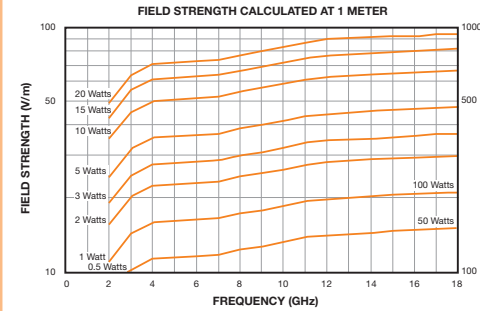

ATH4G8

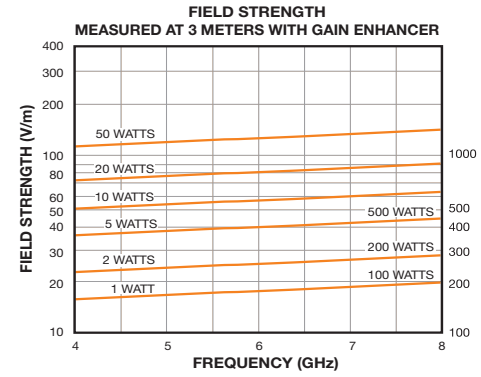
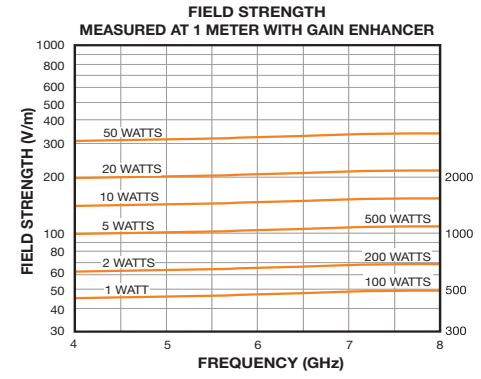

ATH1G18A

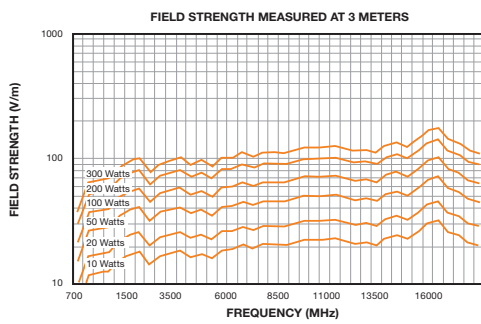
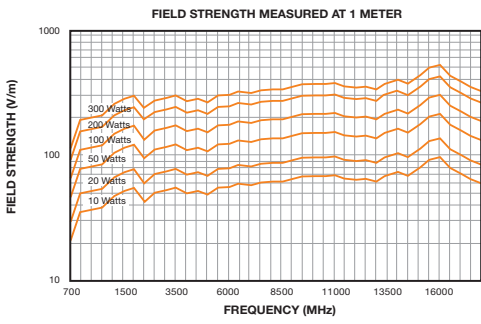

ATH2G8A

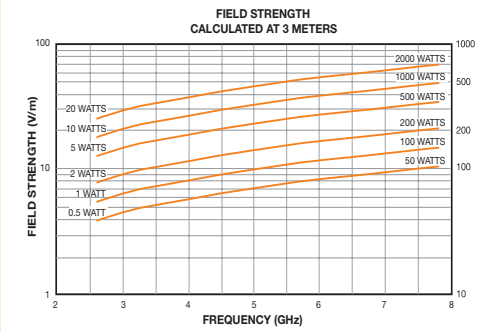
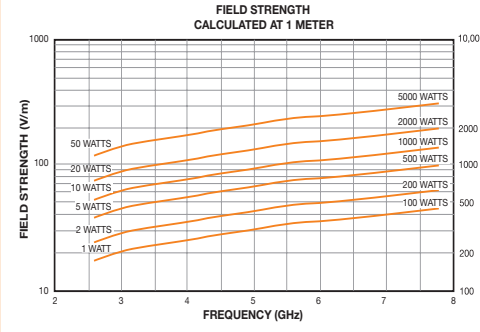

ATH2G8A-1

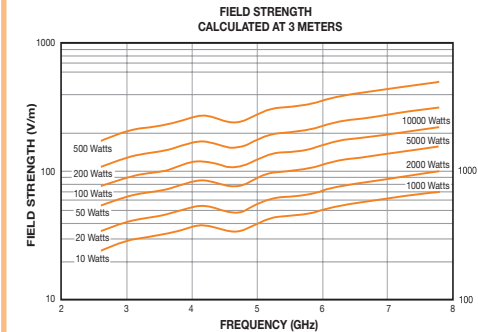
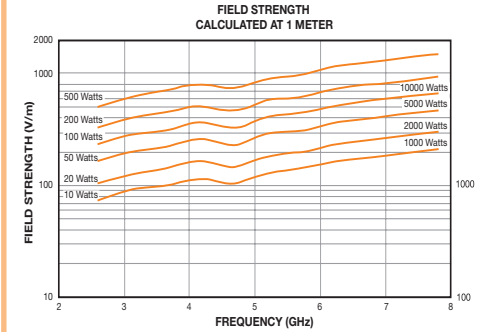

ATH6G18

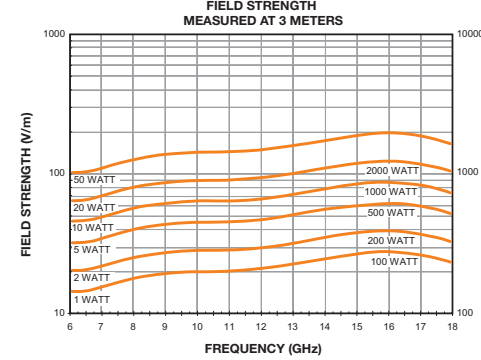
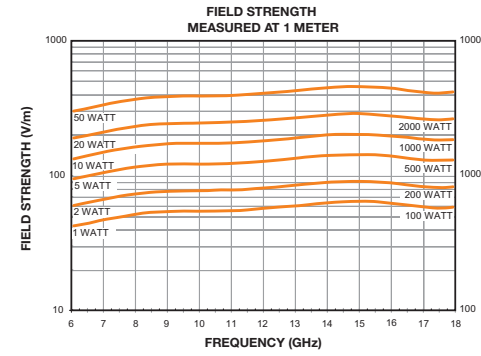

ATH7G18

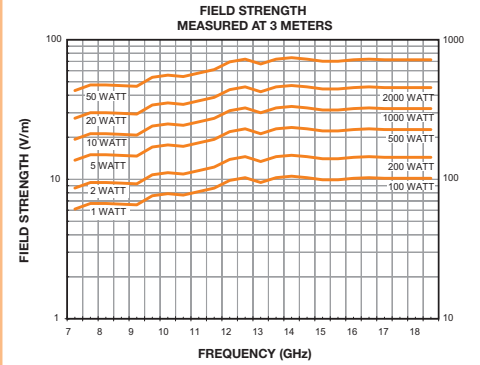
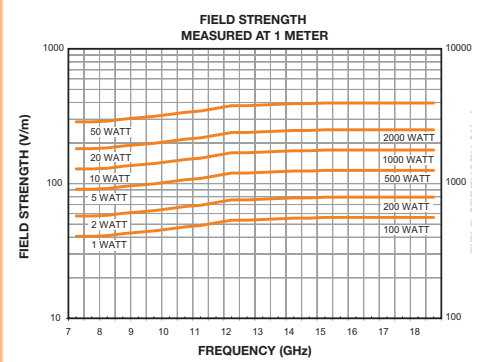

ATH18G27

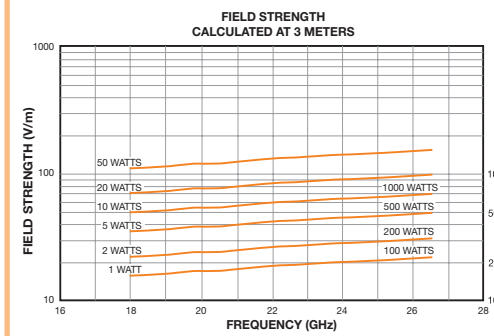
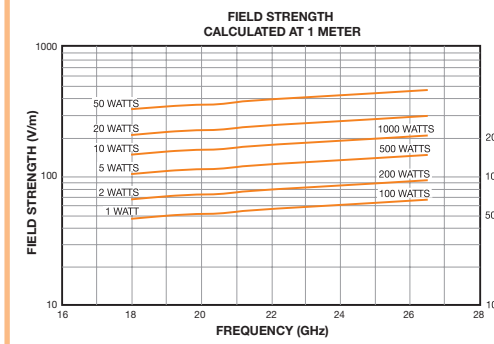

Antennas Microwave Horns. Now To 50 GHz.

ATH18G27-1

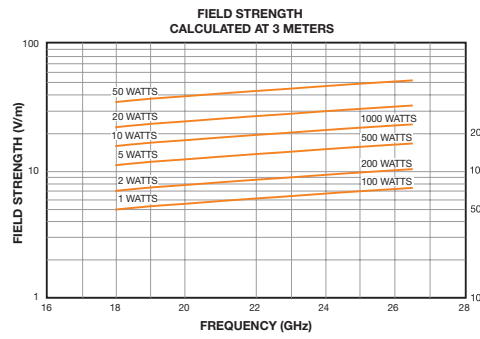
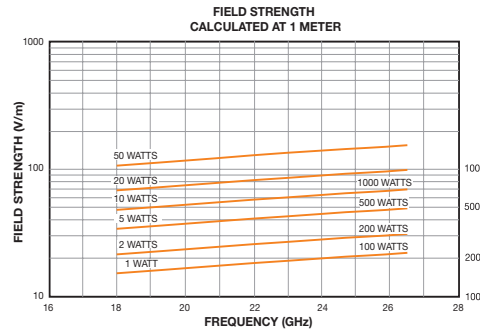

ATH18G40

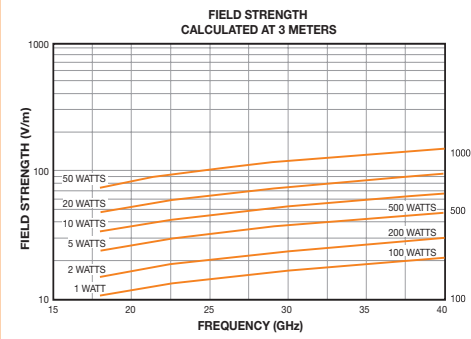
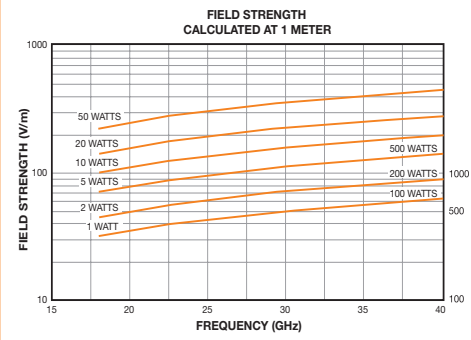

ATH26G40

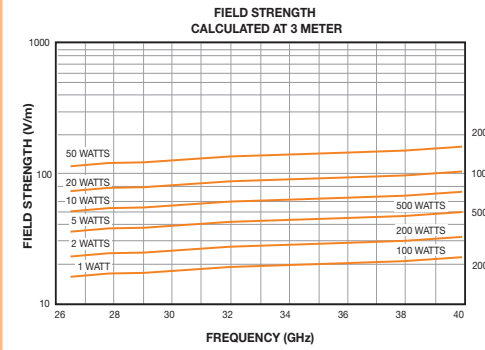
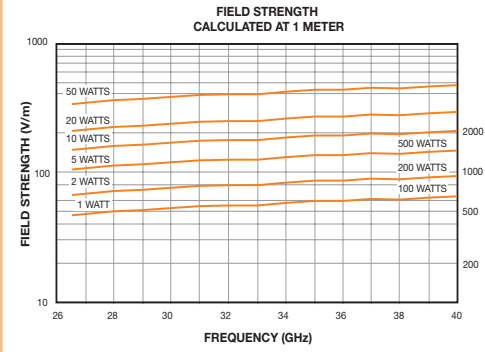

ATH26G40-1

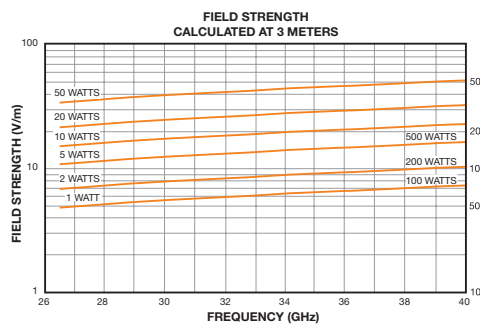
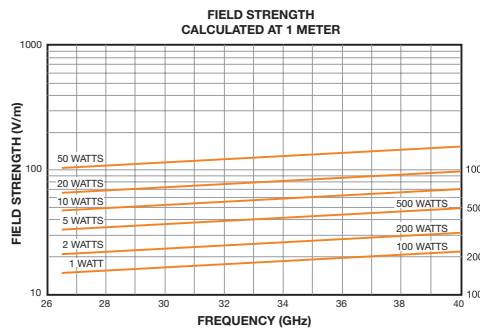

ATH33G50

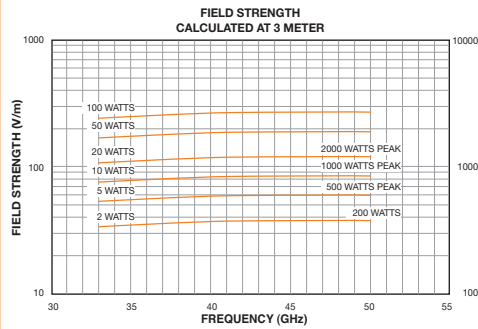
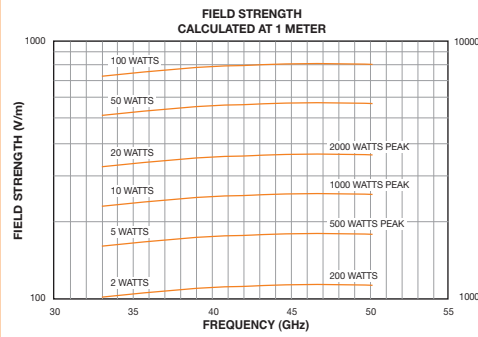

Antennas E-Field Generators. For Uniformity Between The Elements.

ATE10K30MA Our Original Wideband 10 kHz to 30 MHz • Up to 1,000 V/m Between the Elements

The ATE10K30MA E-field generator uses low-inductance, high-power internal load resistors to terminate RF power. An internal broadband balun transformer steps up the output voltage and also decouples the feed line. With optional forced-air cooling, the ATE10K30MA can handle power levels up to 3,000 watts. It is small enough to be handled easily in shielded rooms, but capable of susceptibility testing at intense field levels.

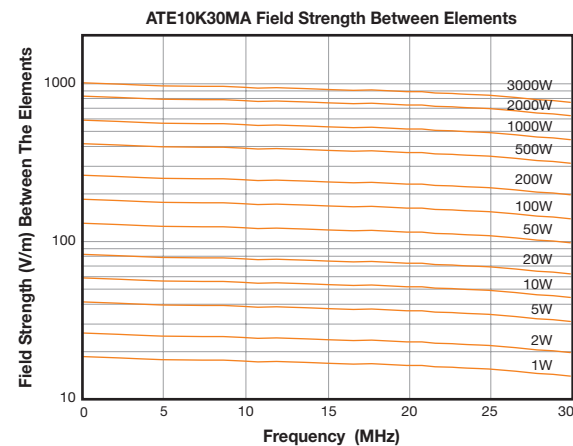

Field strengths shown are typical for free space. Proximity to conductive surfaces and the presence of the device under test will influence actual levels.

ATE10K25M-1 For The BIG Jobs 10 kHz to 25 MHz • To 200 V/m Between the Elements

Practically no job is too large for the ATE10K25M-1 broadband high-power E-field generator. It wraps around cars, small trucks, and other large EUTs. Unbolt the bottom elements from the field generator base to use the ATE10K25M-1 above a ground plane or turn table.



Its high input power and low VSWR capability means the ATE10K25M-1 generates high E-field strengths for the large span between the elements.

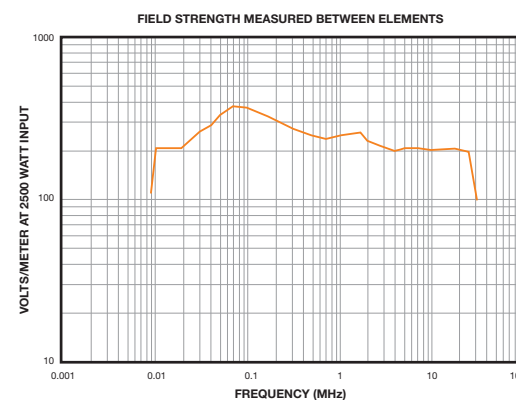

Field strength is shown using AR broadband power amplifiers. Field strengths are typical and do not include cable losses. Individual shielded rooms, reflections, amplifiers, and test-system characteristics will influence performance.

Specifications

Power Input (max)	3,000 watts CW
Frequency Range	10 kHz - 25 MHz
Impedance	50 ohms
VSWR	2.0:1 max, 10 kHz-20 MHz 3.5:1 max, 20 MHz-25 MHz
Electric Field Intensity	200 volts/meter
Connector*	Type C (F)
Size (W x H x D)	303.53 x 222.25 x 101.8 cm (119.5 x 87.5 x 40 in)
Weight (max.)	113 kg (250 lbs)
Mounting Provisions	Optional tripod available

*Adapter C (M)/ N(F) included.

ATE10K100M Evolved Design.

10 kHz to 100 MHz • To 300 V/m
Between the Elements

Our engineers improved upon the parallel element design with this patented extended bandwidth E-field generator. It offers excellent spatial and spectral field uniformity within the defined test zone.

Two sets of elements accommodate a range of EUT sizes. They can be changed quickly and easily, thanks to the specially designed quick-disconnect clamps.

Type A elements provide the highest field intensities and can test objects up to 36 x 46 x 36 cm. The larger elements, Type B, are suitable for testing objects up to 48 x 46 x 36 cm.



FIELD STRENGTH MEASURED BETWEEN TYPE A ELEMENTS

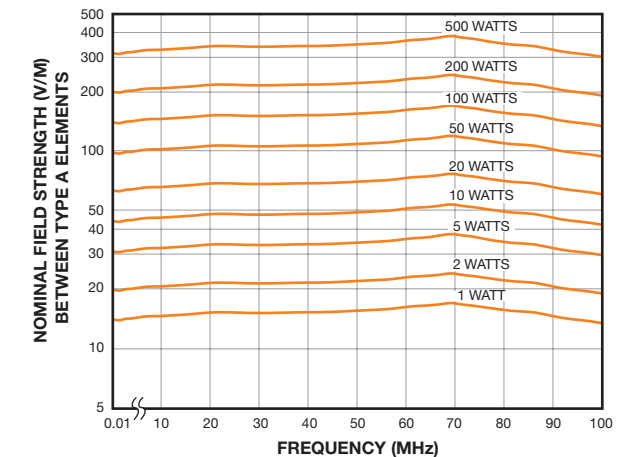

FIELD STRENGTH MEASURED BETWEEN TYPE B ELEMENTS

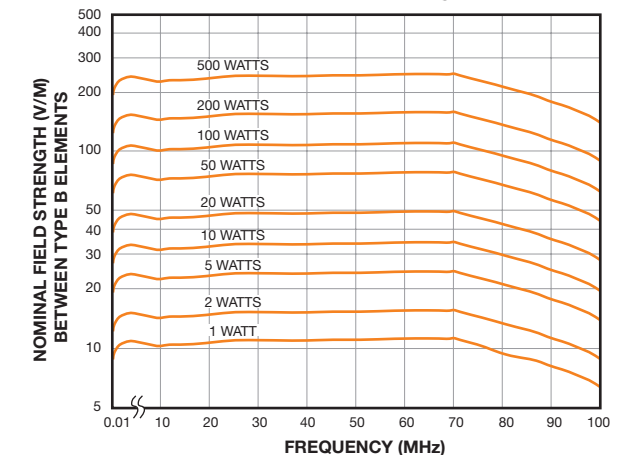

Field strength is shown using AR broadband power amplifiers. Field strengths are typical and do not include cable losses. Individual shielded rooms, reflections, amplifiers, and test-system characteristics will influence performance.

Specifications

Frequency range	10 kHz - 100 MHz
Input Impedance	50 ohms nominal
VSWR	2.5:1 max., 1.4:1 typical
Power input	500 watts max.
Electric field intensity	see graphs
Field Intensity	
between Type A elements	nominally 350 V/m with 500 W input
between Type B elements	nominally 200 V/m with 500 W input
Max. Test Object Volume	
between Type A elements	36 x 46 x 36 cm (14 x 18 x 14 in)
between Type B elements	48 x 46 x 36 cm (19 x 18 x 14 in)
Connector*	Type N (F)
Size	
with Type A elements	74 x 41 x 102 cm (29 x 16 x 40 in)
with Type B elements	104 x 41 x 102 cm (41 x 16 x 40 in)
Weight (max.)	13 kg (28 lb)
Mounting	Accepts tripod threaded 1/4 x 20 stud on three faces (optional tripod available)

*Adapter C (M)/ N(F) included.

Specifications

Frequency range	10 kHz - 30 MHz
Power Input (max)	
without cooling option*	1000 W continuous
with forced-air cooling option*	3000 W, 50% duty cycle
VSWR	
10 kHz - 15 MHz	2.0:1 Max
15 MHz - 22 MHz	3.0:1 Max
22 MHz - 30 MHz	5.0:1 Max
Electric Field Intensity	See graph
Mounting Provisions	UNC 1/4-20 tripod thread on 2 sides (optional tripod available)
Size	188 x 72 x 7.0 cm (74 x 28.3 x 2.5 in) (field-generating elements are removable for storage and transportation)
Weight	
without cooling option	17 kg (38 lbs)
with forced-air cooling	21 kg (46 lbs)
Connector	Type C(F) Quick Change

*See data sheet for higher power operation and alternate duty cycles.

ATP10K100MM4

10 kHz to 100 MHz • To 500 V/m

360° Rotation Accommodates Any Test Object.

The ATP10K100MM4 adds new possibilities to shielded room and anechoic chamber testing with its ability to match free space impedance resulting in efficient production of E&H fields.

The parallel transmission line of the ATP10K100MM4 offers a 377-ohm wave impedance of free space. Matching transformer and load resistors are built in and provide excellent VSWR characteristics over a frequency range of 10 kHz to 100 MHz.

The open area between conductors accommodates entire assemblies within the max. field volume.

Test items too large for insertion between the elements can be brought near the parallel conductors and radiated. The ATP10K100MM4 easily rotates to any horizontal, vertical or diagonal position, and is equipped with height adjustment. Rotation accommodates large EUTs that can't fit between conductors.

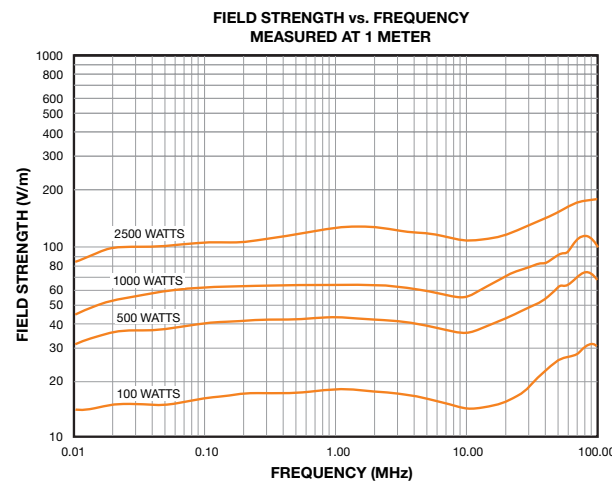
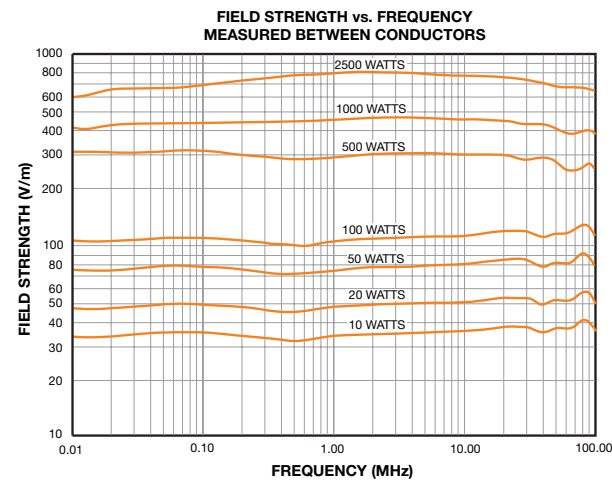

Field strength is shown using AR broadband power amplifiers. Field strengths are typical and do not include cable losses. Individual shielded rooms, reflections, amplifiers, and test-system characteristics will influence performance.

Specifications

Power input (max)	3,000 watts CW
Frequency range	10 kHz - 100 MHz
Input impedance	50 ohms
VSWR	2.0:1 max. 10 kHz - 100 MHz 6:1 max. 10 - 20 kHz above 1kW input power
Electric field intensity	See charts above
Connector	Type 7-16 DIN Female
Cooling	Natural convection to 40°C ambient temperature
Weight	159 kg (350 lb)
Size (W x H x D)	261.1 x 215.4 x 141.7 cm (102.8 x 84.8 x 55.8 in)

Custom Stripline Field Generators

10 kHz to 30 MHz Typical • Up to 20,000 watts

Let AR design a custom stripline system to meet your test needs. Optimum performance is best achieved when all pieces of the system are matched from amplifier through field generation. The results will be guaranteed performance, simplified execution, and best value.

Our engineers will develop the electrical and mechanical design to meet your specific requirements. AR will configure the structural interface to your facility in partnership with your team. And our engineers are highly experienced with 3D electromagnetic simulations, and with high-power RF impedance transformers and low-inductance loads.

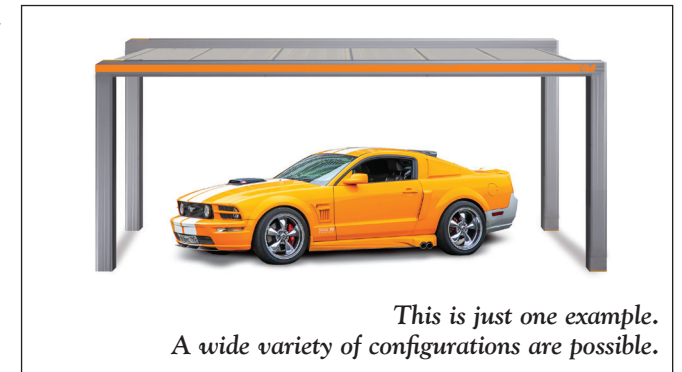

The CAVITENNA : ATC25M1G

25 MHz to 1,000 MHz • To 700 V/m

This is the first RF antenna to make the shielded room an integral part of the radiator. A top-loaded monopole, the Cavitenna, model ATC25M1G, uses the shielded enclosure as a reverberating antenna and the wall as the antenna's ground plane. As a result, the Cavitenna accommodates extremely high power and corresponding field intensities are comparable to those of log-periodic antennas four times its size. In a mode-tuned or mode-stirred reverberation chamber, the Cavitenna's compact design and high efficiency is very effective for lower frequency uses. Its small footprint does not protrude into the test volume as other antenna technologies, such as log-periodic and Biconical antennas.

The Cavitenna extends the lower end of its operational frequency range in some applications. In addition to antenna performance the Cavitenna's ease of use makes it a perfect match for fully automated test configurations. A magnetic mounting clamp is provided to simplify installation in the shielded room.

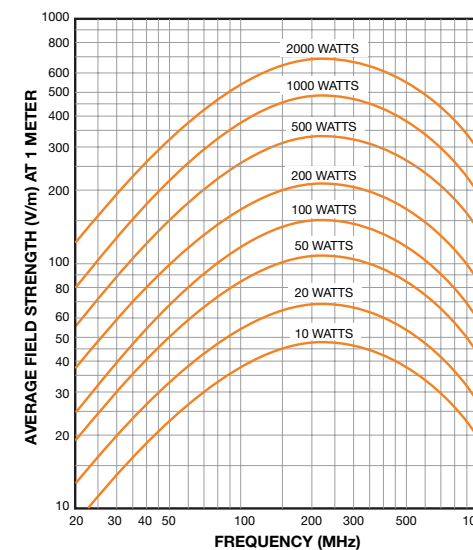

Specifications

Frequency range	25 - 1,000 MHz
Input power (max.)	
25 - 250 MHz	3,500 watts
250 - 500 MHz	2,000 watts
500 - 1000 MHz	1,250 watts
Impedance	50 ohms nominal
Connector	Type C (F)
Electric field intensity	See curves left
Size (W x H x D)	117 x 61 x 51 cm (46 x 24 x 20 in)
Weight (max.)	14 kg (30 lb)
Mounting provisions	Magnetic clamps included

Average field strengths using AR broadband power amplifiers are shown. Field strengths will vary with individual shielded room geometry and placement of the Cavitenna and test item within the room. Consult AR applications engineering or request our Cavitenna Test Report for more information.

The AP5010B Antenna Positioner.

Heavy-duty non-conductive support and positioner for models ATR26M6G, ATR26M6G-1, ATR26M1G or ATR26M250. Built-in casters for easy movement in a shielded room or open site testing. The design also allows the test engineer to position the antenna for either vertical or horizontal polarization, as well as permitting the antenna to be tilted 30 degrees. Height adjustment is from 2.07m (81.69 in) to 3.31m (130.25 in), measured from the floor to the center line of antenna. The AP5010B is equipped with base leg adjustment from 1.53m (60.19 in) overall to 2.04m (80.19 in).

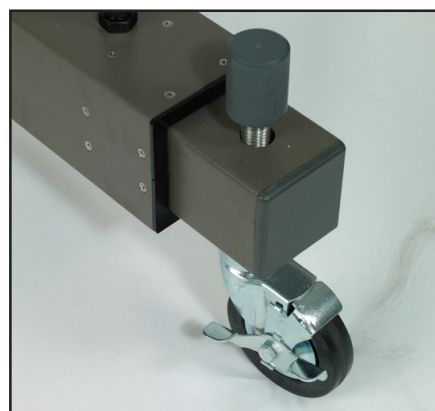
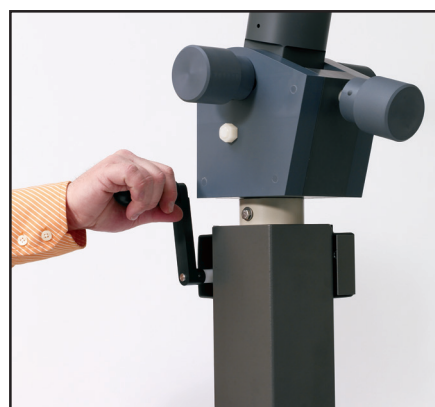

TP3000 Standard Tripod.

The Model TP3000 is a high-quality wooden-legged tripod for use in RF generation and measuring applications. The majority of the tripod is non-metallic which minimizes the effect the tripod has on an RF field, which allows more accurate measurements. This tripod is ideal for use with the SM40G and SM400K Safety Meters, or in other applications where a non-conductive tripod is preferable. Adjustable legs allow for leveling of the tripod.

Specifications

Load Capacity:	10 Kg (22 Lbs)
Maximum Height (Approx.):	182 Cm (72 In)
Minimum Height (Approx.):	53 Cm (21 In)
Column Travel:	45 Cm (18 In)
Leg Sections:	3
Pan Rotation:	360°
Instrument Mounting Screw:	1/4" X 20
Material:	Wood
Weight:	2.6 Kg (5.8 Lbs)
Export Classification:	Ear99



The TP1000B tripod.

Our lightweight, nonconductive tripod supports many antennas. Angle, level and height are easily adjustable. The adjustable mount makes it simple to change antenna polarization. The TP1000BMI comes with locking casters and an additional swivel adapter head. AR offers other tripods including models TP2000, TP2010 and TP4000. For more information on these models, visit our website.

The TM 1000 Series Antenna Adapters.

AR also provides antenna adapters that allow bore sight rotation of microwave horn antennas. The TM series is compatible with AR Model TP1000B tripod.

TM1000: For WRD-750 D24 waveguide and ATH7G18.

TM1001: For WR-42 waveguide and ATH18G27 and ATH18G27-1

TM1002: For WR-28 waveguide and ATH26G40 and ATH6G40-1

TM1003: For WRD-180 waveguide and ATH18G40

TM1004: For WRD-250 D30 waveguide and ATH2G8A

AP4000

The AP4000 Antenna positioner is a heavy-duty positioner for AR's ATH200M1G, 200 to 1,000 MHz high-gain horn antenna. The height is easily adjustable and it rotates to change polarization. The AP4000 is built on wheels for easy movement in a shielded room or at free space testing. Also available is a 3-meter height positioner for the ATH200M1G antenna.